

Item	Qty.	Description
1	1	37" S40 Vertical Extrusion
2	1	37" S40 Vertical Extrusion
3	1	16" S40 Horizontal Extrusion
4	1	16" Z31 Horizontal Extrusion
5	1	16" Z31 Horizontal Extrusion
6	1	37" Z31 Horizontal Extrusion
7	1	37" Z31 Horizontal Extrusion
8	1	37" Z31 Horizontal Extrusion
9	1	37" Z31 Horizontal Extrusion

Steps:

- 1) Attach horizontal [3] and [4] between verticals [1] and [2].
- 2) Slide **Infill** between verticals [1] and [2] and set on [4].
- 3) Attach horizontal [5] between verticals [1] and [2] and on top of Infill.
- 4) Attach horizontals [6] [7] and [8] between [1-5] assembly and Panel.
- 5) Slide **Infill** between [1-5] assembly and Panel, then secure with [9].
- 6) Set Shelf onto lower horizontals [4] [6] and [8].
- 7) Place Counter Top on upper horizontals [5] [7] and [9].
- 8) Attach Literature Pockets to Panel, using Screw Caps.

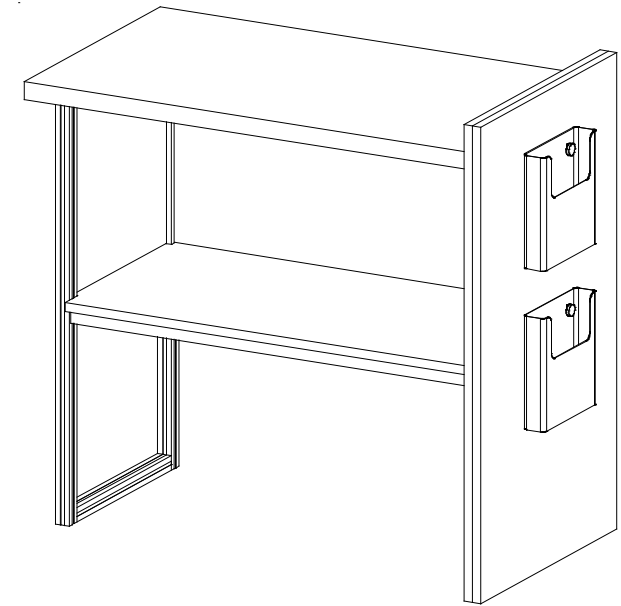

Completed Assembly

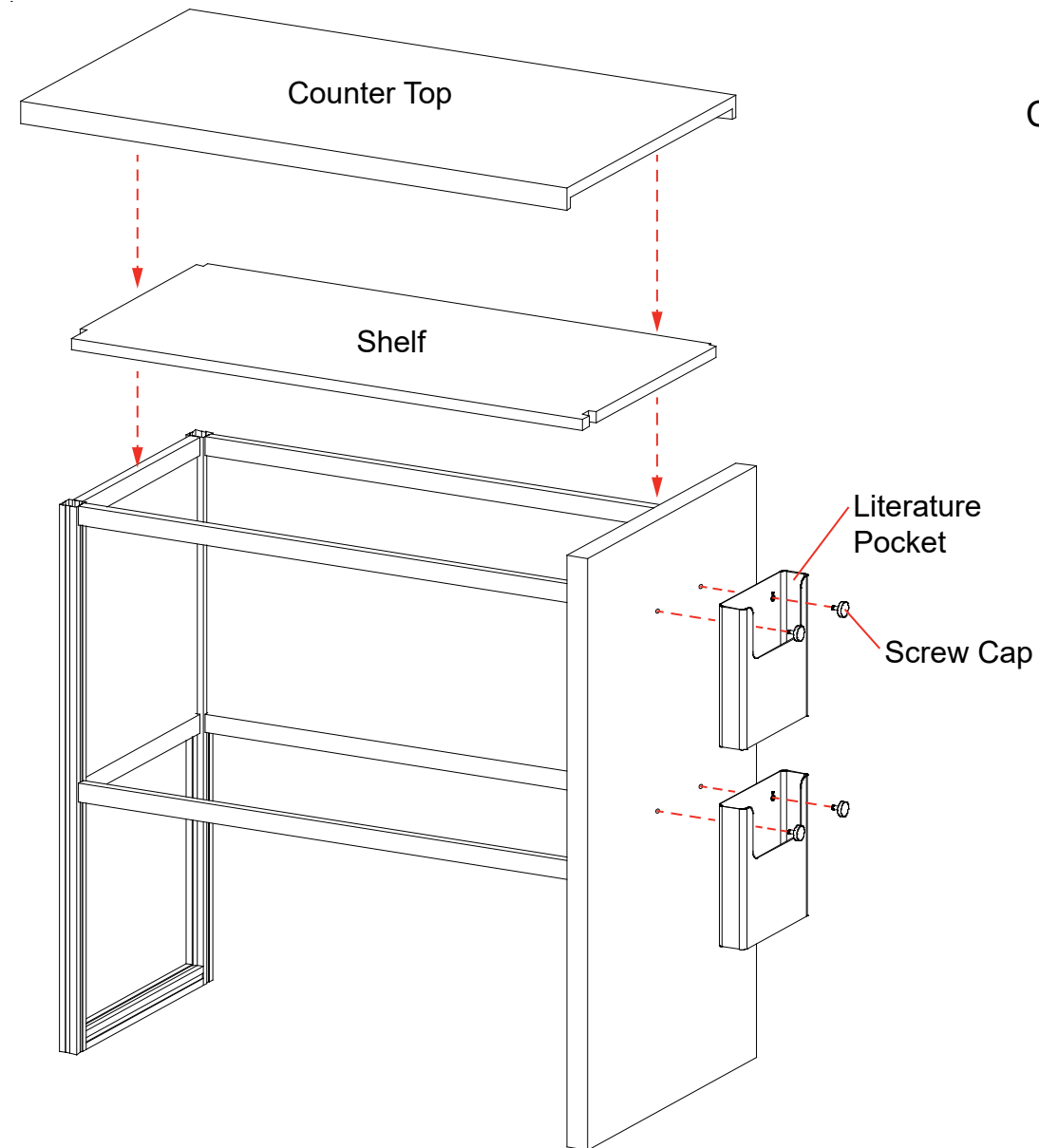
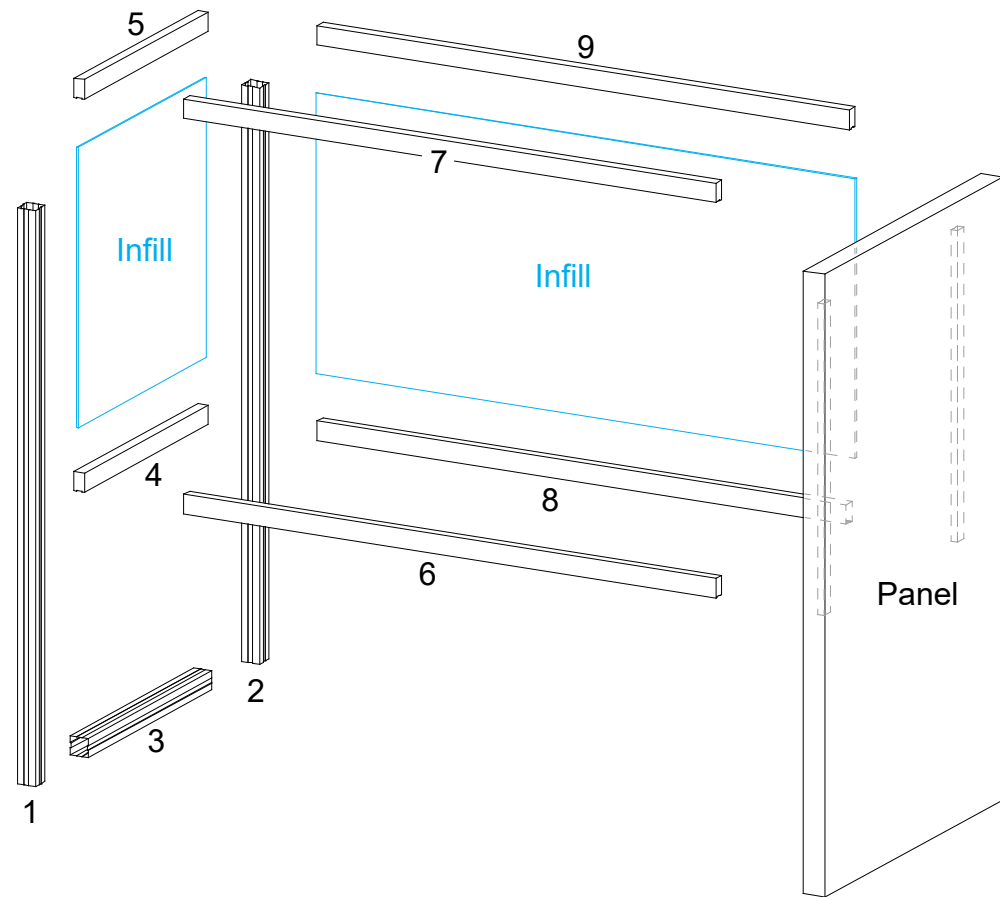

SETUP INSTRUCTIONS

General Setup Instructions

- Read entire setup instruction manual prior to unpacking parts and pieces.
- The setup instructions are created specifically for this configuration.
- Setup instructions are laid out sequentially in steps, including exploded views with detailed explanation for assembly.

Cleaning & Packing

- For Cleaning Metal, Plex, & Laminate Parts: Use a **MILD NON-ABRASIVE** cleanser and soft cloth/paper towel to clean all surfaces.
- Keep exhibit components away from heat and prolonged sun exposure. **Heat and UV exposure will warp and fade components.**
- Retain all provided Packing Materials. All provided packing materials are for ease of repacking & component protection.

Disassembly

- For loss prevention, tighten all set screws and locks during disassembly.

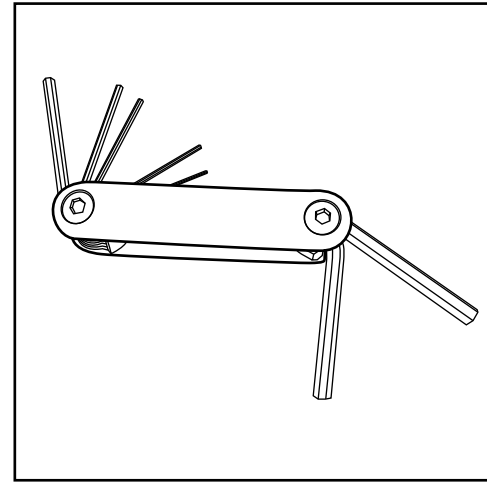

Hex Tool - Essential for Assembly

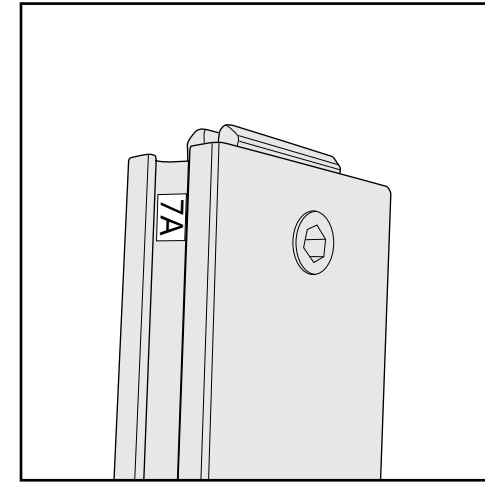

Part Identification - Numbering

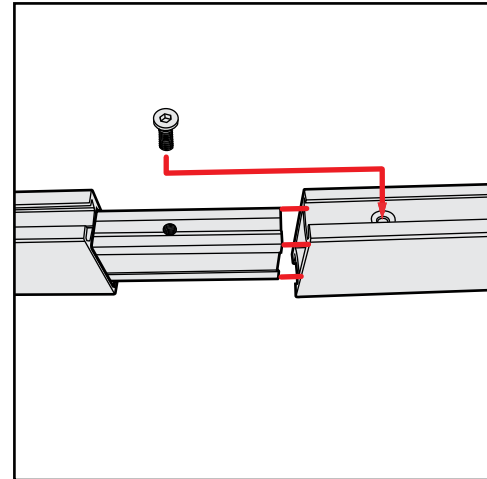

Spline Connection

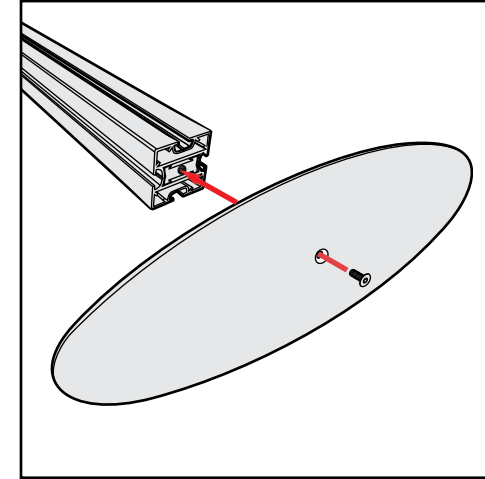

Base Plate & Extrusion Connection

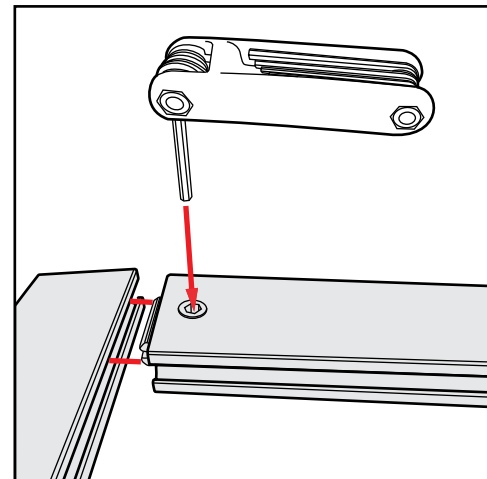

Extrusion & Lock Connection

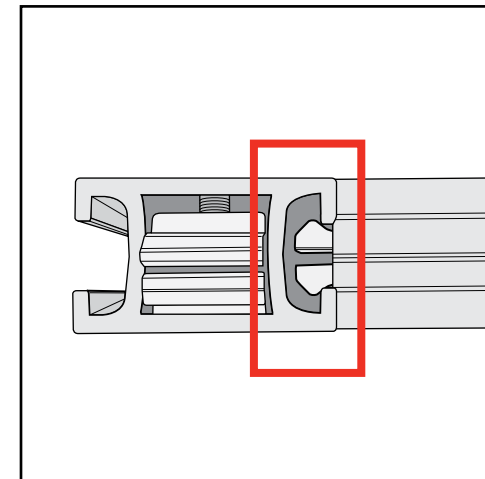

Engaged Lock



WARNING

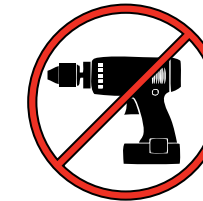

DO NOT USE POWER TOOLS



LADDERS OR LIFTS
MAY BE REQUIRED



ALL CONNECTIONS MUST
BE TIGHTLY SECURED

Top View of Each Level

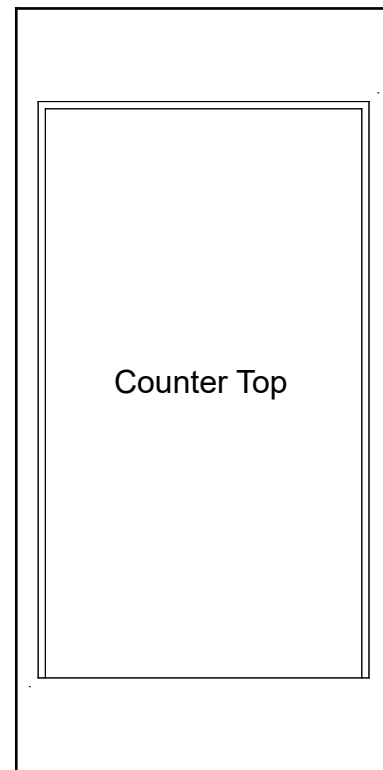

Level 1

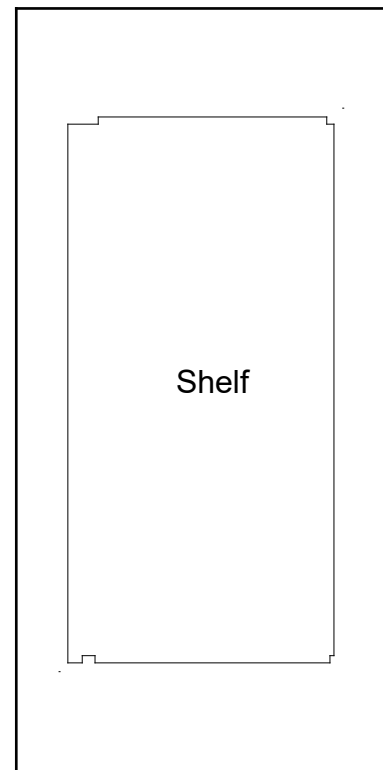

Level 2

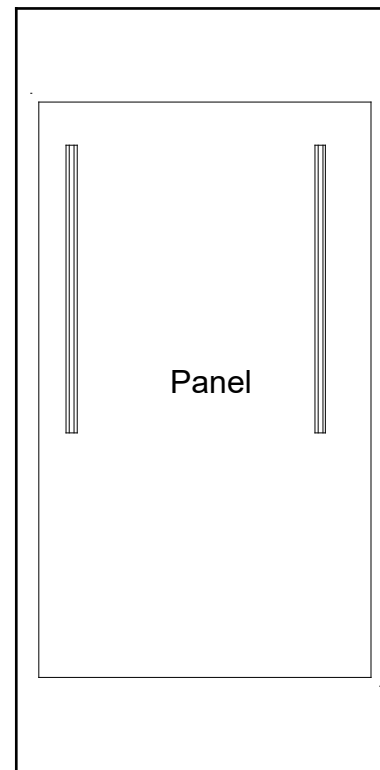

Level 3

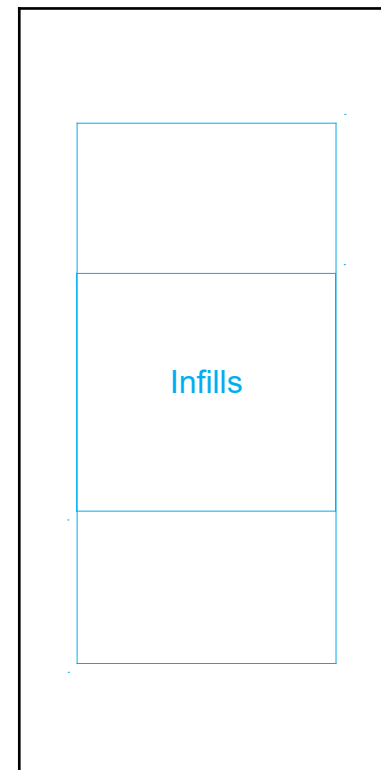

Level 4

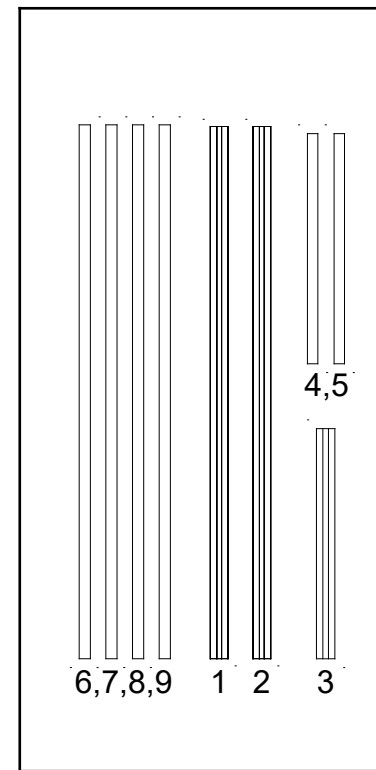

Level 5

