

| Item | Qty. | Description |
|------|------|--------------------------------|
| 1/1A | 1/1 | 36.4882”h Vertical Extrusion |
| 2/2A | 1/1 | 42”h Vertical Extrusion |
| 3/3A | 1/1 | 42”h Vertical Extrusion |
| 4/4A | 2/2 | 40”w Z45 Horizontal Extrusion |
| 5/5A | 2/2 | 13”w Z45 Horizontal Extrusion |
| 6/6A | 2/2 | 5”w Z140 Horizontal Extrusion |
| 7/7A | 1/1 | 40”w Z140 Horizontal Extrusion |

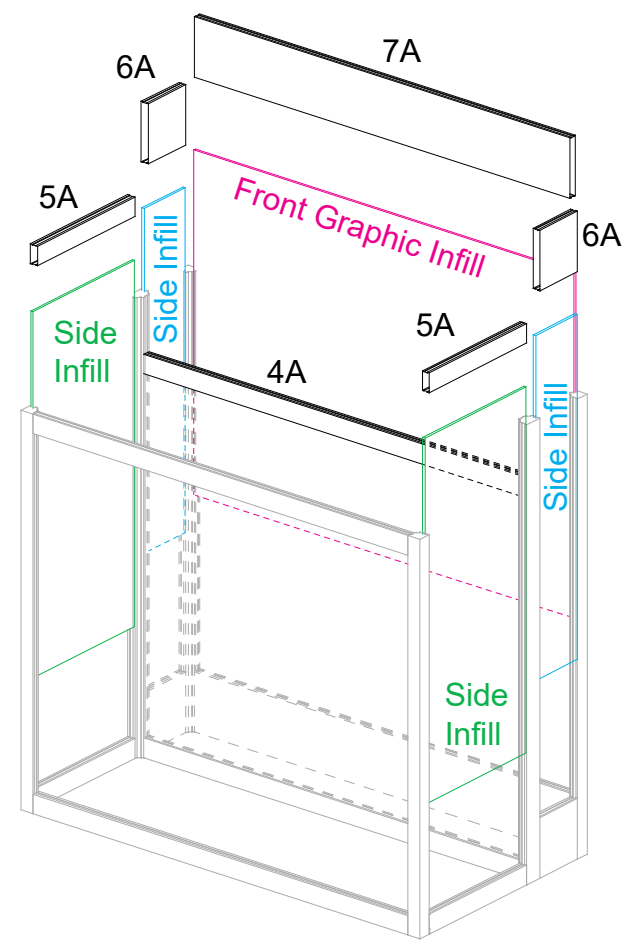
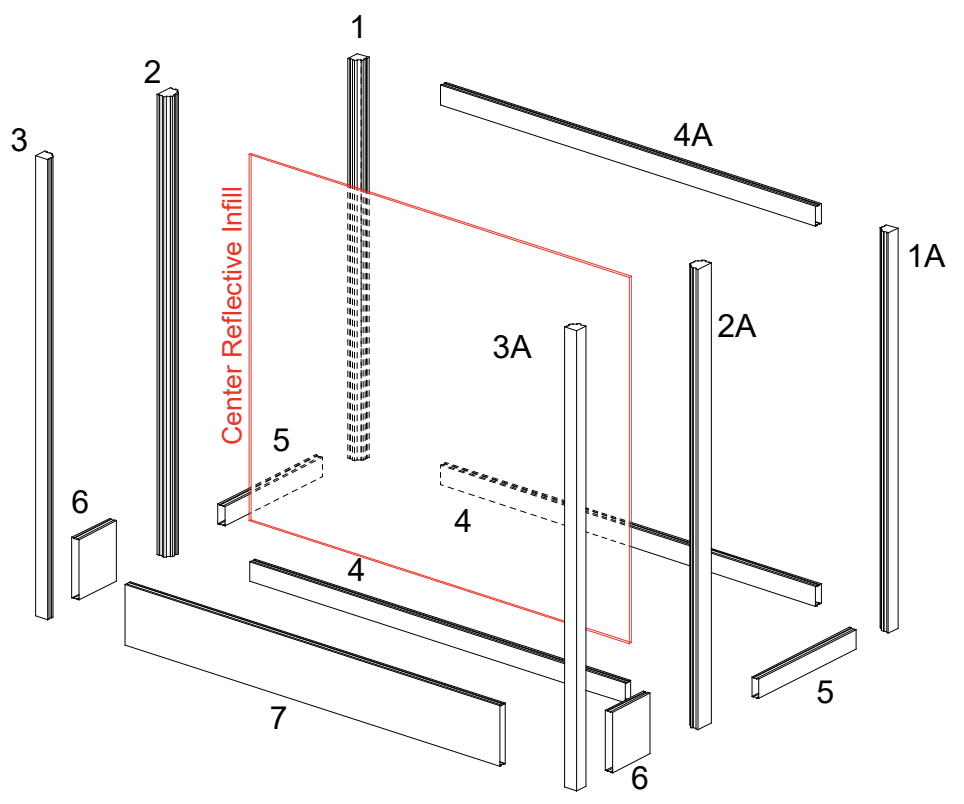

Steps:

- 1) Connect horizontals [4] & [4A] between verticals [1] & [1A].
- 2) Attach horizontal [4] between verticals [2] & [2A].
- 3) Connect horizontals [5] between verticals [1 & 2] & [1A & 2A].
- 4) Attach horizontal [7] between verticals [3] & [3A].
- 5) Connect horizontals [6] between verticals [1 & 2] & [2A & 3A].
- 6) Slide **Center Reflective Infill** between verticals [2] & [2A]; secure with horizontal [4A].
- 7) Insert **Side Infills** between verticals [1 & 2] & [1A & 2A]; secure with horizontals [5A].
- 8) Insert **Side Infills** between verticals [2 & 3] & [2A & 3A]; secure with horizontals [6A].
- 9) Insert **Front Graphic Infill** between verticals [3 & 3A].
- 10) Place Internal Shelf on shelf pins.
- 11) Attach Primary Counter Top to top of assembled base.
- 12) Connect Plex Counter Top to top of verticals [2/3] & [2A/3A].
See **Plex Counter Top Attachment** detail.

*** Plex Counter Attachment**

Insert Connector into groove.
Place Plex Counter on top of pedestal base.
Secure counter with Screw Cap.

****DO NOT OVER TIGHTEN. PLEX WILL CRACK****

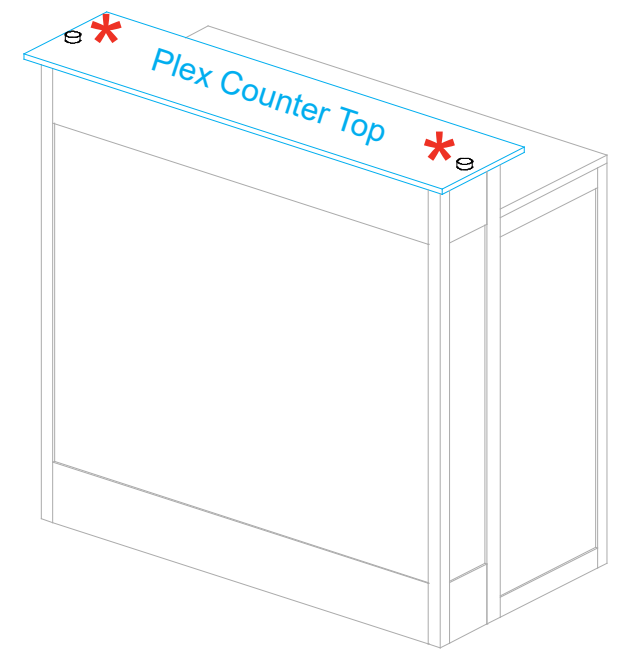
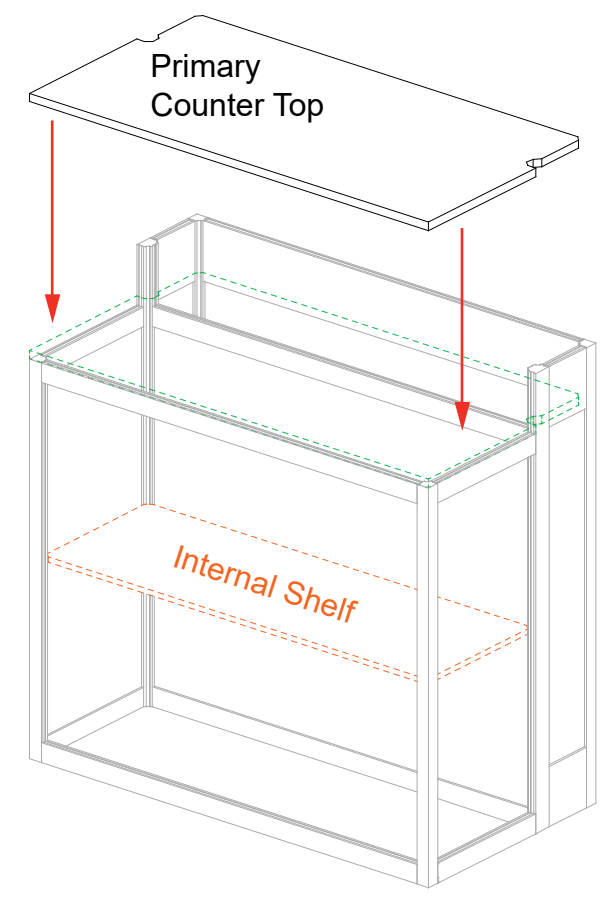

SETUP INSTRUCTIONS

General Setup Instructions

- Read entire setup instruction manual prior to unpacking parts and pieces.
- The setup instructions are created specifically for this configuration.
- Setup instructions are laid out sequentially in steps, including exploded views with detailed explanation for assembly.

Cleaning & Packing

- For Cleaning Metal, Plex, & Laminate Parts: Use a **MILD NON-ABRASIVE** cleanser and soft cloth/paper towel to clean all surfaces.
- Keep exhibit components away from heat and prolonged sun exposure. **Heat and UV exposure will warp and fade components.**
- Retain all provided Packing Materials. All provided packing materials are for ease of repacking & component protection.

Disassembly

- For loss prevention, tighten all set screws and locks during disassembly.

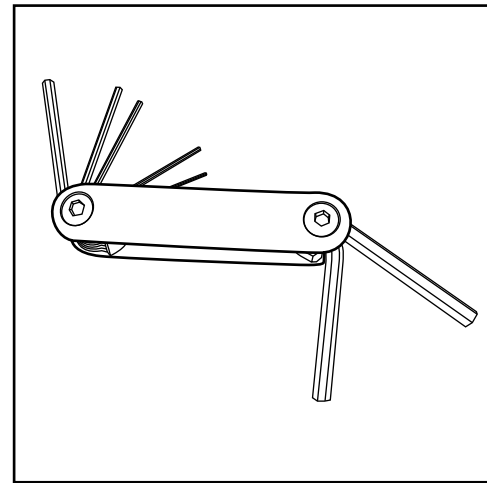

Hex Tool - Essential for Assembly

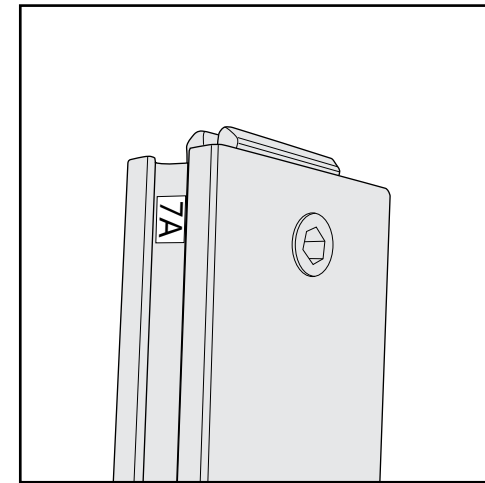

Part Identification - Numbering

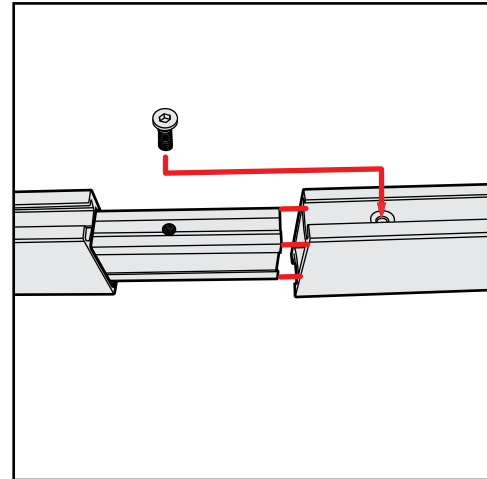

Spline Connection

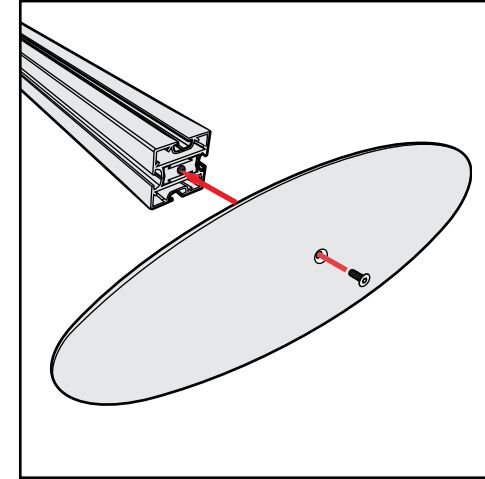

Base Plate & Extrusion Connection

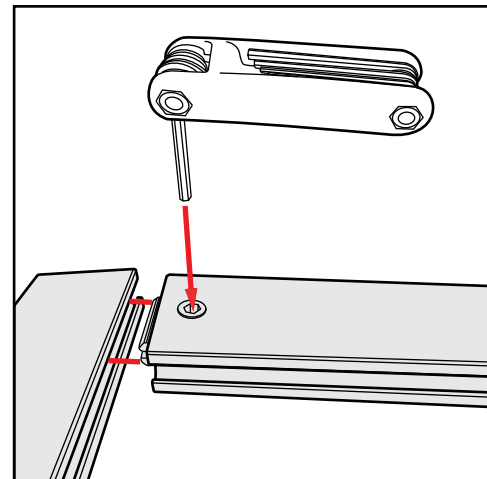

Extrusion & Lock Connection

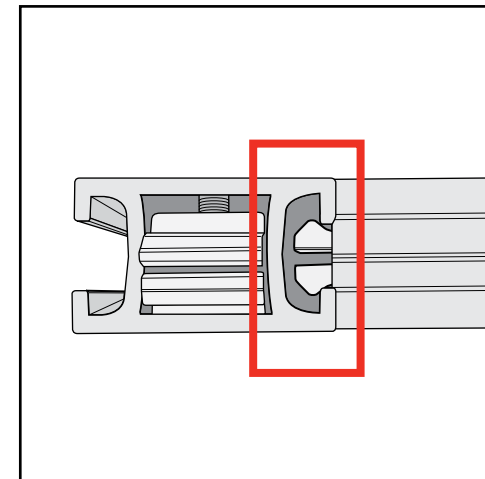

Engaged Lock



WARNING



DO NOT USE POWER TOOLS

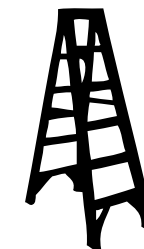

LADDERS OR LIFTS
MAY BE REQUIRED



ALL CONNECTIONS MUST
BE TIGHTLY SECURED